

Schwank
INNOVATIVE HEATING SOLUTIONS

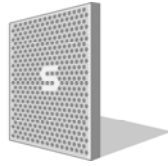

infrasave
radiant heaters

builderSchwank Series S100 Models

Builder Series ITB Models

GAS-FIRED LOW INTENSITY TUBE TYPE
INFRA RED HEATERS

REPLACEMENT PARTS LIST

NOTICE:

The manufacturer reserves the right to make changes to equipment and specifications without obligation of notification.

This publication or parts thereof may not be reproduced in any form without prior written consent from the manufacturer. Unauthorized use or distribution of this publication is strictly prohibited.

Customer & Technical Services:

1-877-446-3727
Fax: 1-866-361-0523
csr@schwank.com

Schwank and InfraSave brand products
www.SchwankUSA.com
www.Schwank.ca
www.InfraSave.com



FOR YOUR SAFETY:

This heater must only be serviced by a trained gas service technician. Failure to comply could result in personal injury, death, fire and/or property damage.

Burner Components Builder Model S100 / ITB

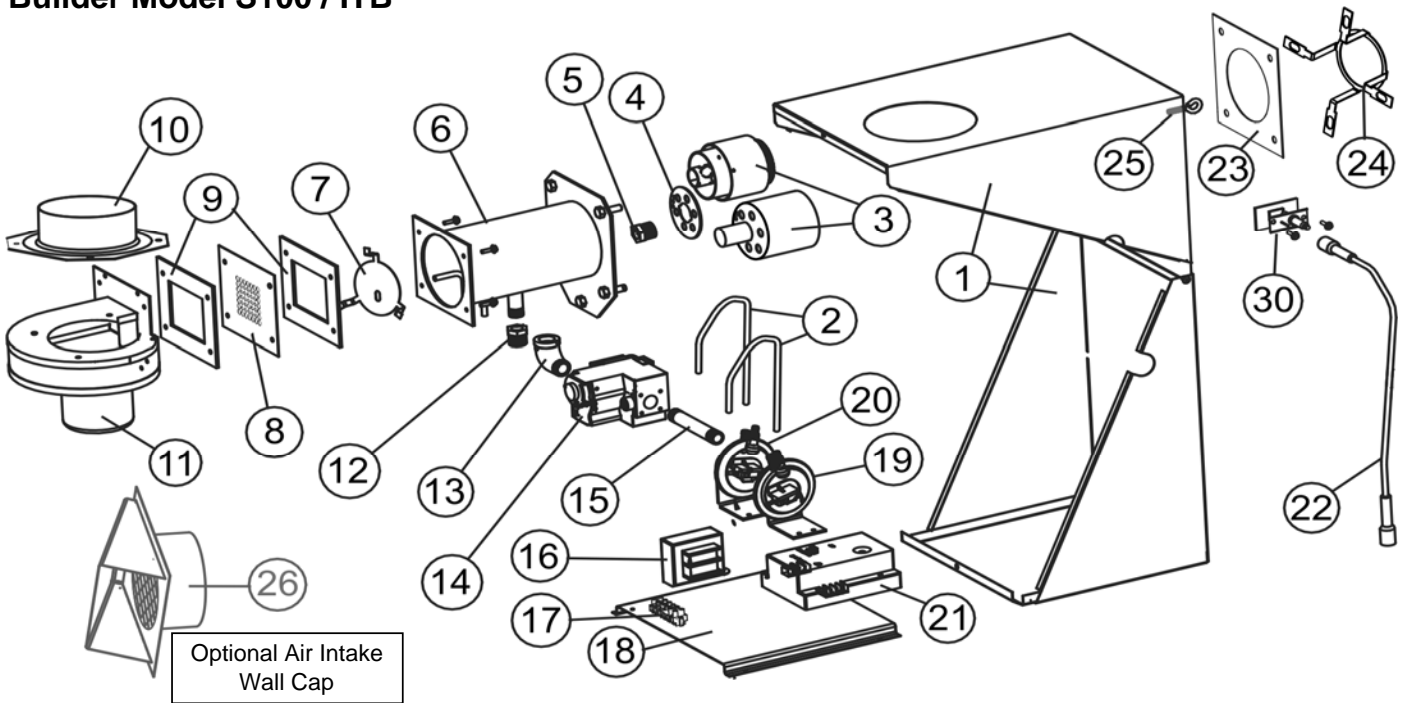

#	PART DESCRIPTION	MODEL	MODEL DASH #/ GAS TYPE	PART #	PART DESCRIPTION PRIMARY
1	BURNER HOUSING	ALL	Schwank	JS-0582-XX	Burner housing coated orange
		ALL	Infrasave	JJ-0582-XX	Burner housing coated gray
2	PRESSURE SWITCH TUBING	ALL		JS-0572-SE	Tubing set 2 x 20" PVC SE
3	BURNER CUP	45	NG; LP	JS-0510-LP-45	Burner Cup w/ Center Hole
		60, 80, 100	NG; LP	JS-0510-LP	Burner Cup
		110-155	NG; LP	JS-0512-XX	Burner Cup
		175	NG	JS-0512-XX	Burner Cup
		175	LP	JS-0512-UL	Burner Cup - Cast Aluminum - No Hole
		200	NG; LP	JS-0512-UL	Burner Cup - Cast Aluminum - No Hole
4	BURNER CUP AIR RESTRICTOR RING	45	NG; LP	JS-0596-AA	Burner Cup air restr ring 9/32"
		60	LP	JS-0596-XX	Burner Cup air rest ring 0.375
		60-175	NG	JS-0596-XX	Burner Cup air rest ring 0.375
		80-155	LP	JS-0597-XX	Burner head air rest. ring .500
		175	-S; LP	JS-0597-XY	Burner Cup air rest ring 175-S LP
		200	-S; LP	JS-0597-YE	Burner Cup air rest ring 200-S LP
		200	-S; NG	JS-0597-YY	Burner Cup air rest ring 200-S NG
5	MAIN BURNER ORIFICE	45	LP	JS-0748-DM	Gas orifice low intensity HR 48 DMS
		45	NG	JS-0730-DM	Gas orifice low intensity HR 30 DMS
		60	LP	JS-0742-DM	Gas orifice low intensity HTR 42 DMS
		60	NG	JS-0725-DM	Gas orifice low intensity HTR 25 DMS
		80	LP	JS-0736-DM	Gas orifice low intensity HTR 36 DMS
		80	NG	JS-0718-DM	Gas orifice low intensity HTR 18 DMS
		100, 110	LP	JS-0731-DM	Gas orifice low intensity HTR 31 DMS
		100, 110	NG	JS-0752-MM	Gas orifice low intensity HTR 5.2 mm

continued ...

#	PART DESCRIPTION	MODEL	MODEL DASH #/ GAS TYPE	PART #	PART DESCRIPTION PRIMARY
5	MAIN BURNER ORIFICE	130	LP	JS-0729-DM	Gas orifice low intensity HTR 29 DMS
		130	NG	JS-0758-MM	Gas orifice low intensity HTR 5.8 mm
		155	LP	JS-0714-IN	Gas orifice low intensity HTR 9/64 inch
		155	NG	JS-0725-IN	Gas orifice low intensity HTR 1/4 inch
		175	LP	JS-0724-DM	Gas orifice low intensity HTR 24 DMS
		175	NG	JS-0767-MM	Gas orifice low intensity HTR 6.7 mm
		200	LP	JS-0719-DM	Gas orifice low intensity HTR 19 DMS
		200	NG	JS-0730-IN	Gas orifice low intensity HTR 19/64 inch
6	BURNER CHAMBER	ALL		JS-0504-XX	Burner Chamber
7	BURNER AIR RESTRICTOR	45	NG & LP	JS-0592-AR	Burner air restrictor (45 Only)
8	EQUALIZER PLATE	45	LP	JS-0593-XL	Outlet equalizer plate 45 LP - 29 Holes
		45	NG	JS-0593-NG	Outlet equalizer plate 45 NG - 25 Holes
		60 to 155	NG & LP	JS-0593-XX	Outlet equalizer plate 60 to 155 LP & NG
		175	LP	JS-0593-XY	Outlet equalizer plate 175-S LP
		175	NG	JS-0593-XX	Outlet equalizer plate 175 NG
		200	NG & LP	JS-0593-XE	Outlet equalizer plate 200-S LP & NG
9	BLOWER GASKET	ALL	<i>Each</i>	JS-0578-XX	Outlet blower gasket
10	AIR INLET C/W SCREEN	45	NG	JS-0595-SC	Air Inlet Adapter 45 NG
		45	LP	JS-0594-ST	Air Inlet Adapter 45 LP
		60	NG & LP	JS-0594-ST	Air Inlet Adapter 60 NG & LP
		80	NG & LP	JS-0595-SP	Air Inlet Adapter 80 NG & LP
		100	NG	JS-0595-SP	Air Inlet Adapter 100NG
		110 to 200	NG & LP	JS-0595-AA	Air Inlet Adapter 110-200 NG & LP
11	BLOWER ASSEMBLY	45 to 175		JS-0579-AA	Blower Assembly 1/35 HP - 45 to 175
		200		JS-0579-ZZ	Blower Assembly 1/20 HP - 200,000
12	MANIFOLD BUSHING	ALL		JM-0589-XX	Manifold bushing
13	90 DEGREE ELBOW FITTING 1/2"	ALL		JS-0588-XX	Street elbow fitting 90 deg
14	GAS VALVE	45 to 155	NG	JL-0701-AA	Valve gas comb 3.5" WC 24VAC VR8 NG
		45 to 155	LP	JL-0703-AA	Valve gas comb 10" WC 24VAC VR8 LP
		175, 200	NG	JA-0506-XX	Gas Valve - Slow Open 3.5" WC NG
		175, 200	LP	JA-0507-XX	Gas Valve - Slow Open 10" WC LP
15	4" NIPPLE	ALL		JS-0590-XX	Nipple 4"
16	TERMINAL BLOCK	ALL		JM-0455-DD	Terminal block
17	STEP DOWN TRANSFORMER	ALL		JA-0775-XX	Transformer 120/24V, 20VA AT120B1028
18	COMPONENT PLATE	ALL		JS-0581-XX	Component mounting plate SE
19	COMBUSTION AIR PROVING SWITCH	45	-C; -UH	JS-0576-XX	Air proving Switch 0.48" WC
		45	-X1	JS-0576-AA	Air proving Switch 0.85" WC
		60		JS-0576-YY	Air proving Switch 0.30" WC
		80		JS-0576-XX	Air proving Switch 0.48" WC
		110		JS-0575-YY	Air proving Switch 0.65" WC
		110	-FB	JS-0575-ZB	Air proving Switch 0.90" WC
		130		JS-0575-YY	Air proving Switch 0.65" WC
		130	-FB	JS-0576-UL	Air proving Switch 1.10" WC
		155		JS-0575-YY	Air proving Switch 0.65" WC
		155	-A	JS-0575-UG	Air proving Switch 1.00" WC
		175	-S; NG	JS-0576-AA	Air proving Switch 0.85" WC
		175	-S; LP	JS-0576-XY	Air proving Switch 1.15" WC
		200	-S	JS-0575-ZA	Air proving Switch 1.40" WC

#	PART DESCRIPTION	MODEL	MODEL DASH #/ GAS TYPE	PART #	PART DESCRIPTION PRIMARY
20	BLOCKED FLUE PRESSURE SWITCH	45	-X1	JS-0577-YY	Blocked flue switch 0.90" WC
		45	-C; -UH	JS-0577-ZZ	Blocked flue switch 1.41" WC
		60	NG; LP	JS-0577-SS	Blocked flue switch 0.58" WC
		110	-FB	JS-0578-UL	Blocked flue switch 1.03" WC
		130	-FB	JS-0577-XZ	Blocked flue switch 1.25" WC
		80-155	NG; LP	JS-0577-YY	Blocked flue switch 0.90" WC
		175	-S; NG	JS-0577-ZZ	Blocked flue switch 1.41" WC
		175	-S; LP	JS-0577-XY	Blocked flue switch 1.20" WC
		200	-S; LP	JS-0577-UW	Blocked flue switch 1.33" WC
		200	-S; NG	JS-0577-ZZ	Blocked flue switch 1.41" WC
21	See below - Confirm Make of Ignition Control installed in burner				
22					
23	FLAME RECTIFICATION PLATE	175	-S LP	JS-0591-XY	Flame Rectifier Plate 175-S LP
24	FLAME RECTIFICATION	110	-FB	JS-0592-RT	Flame Rectifier 110, 130 -FB Models
		130	-FB	JS-0592-RT	Flame Rectifier Plate 175-S LP
		200	-S LP	JS-0592-RX	Flame Rectifier 200-S LP
25	EYE BOLT	ALL		JF-1012-EB	Eye Bolt
26	COMBUSTION AIR INLET WALL CAP 4"	ALL	OPTIONAL	JS-0532-VC	Fresh air intake horizontal (wall) vent cap 4"
30	IGNITER KIT	ALL		JA-0571-KT	Igniter & gasket kit / DSI tube heater

Burners with FENWAL IGNITION CONTROL - Models: S100-F; ITB-F

20	FENWAL DSI CONTROL	ALL		JA-0567-XX	3-Trial 24Vac with blower relay
	REPLACEMENT KIT: FENWAL replaces S87J	ALL		JA-0568-KT	Fenwal Control + Wire Harness + Cable + Igniter: Replaces S87J
21	IGNITION CABLE	ALL		JS-0518-SA	Hi voltage wire (24") STW - 2 x 1/4" Spades

BURNERS WITH HONEYWELL S87-J IGNITION CONTROL

20	IGNITION CONTROL	S87J DISCONTINUED		JA-0568-XX	Control DSI 24VAC S87J-1034
	REPLACEMENT KIT: FENWAL replaces S87J			JA-0568-KT	Fenwal Control + Wire Harness + Cable + Igniter: Replaces S87J
21	IGNITION CABLE HONEYWELL S87J			JS-0518-XX	Wire high voltage (24") S87J Bullet Connection

BURNERS WITH CHANNEL GASLITER 50N IGNITION CONTROL

20	IGNITION CONTROL			JB-0568-AA	Control - DSI 3 Try potted Gasliter 50N 50N-24-3-30-20-30-30,24VAC 1,1A
21	IGNITION CABLE			JS-0518-SA	Hi voltage wire (24") STW - 2 x 1/4" Spades
	IGNITION CONTROL WIRING HARNESS			JB-0568-WH	3 Try potted spark DSI control wiring harness
	WIRING KIT (not shown)			JW-WXXX-HX	Wiring kit w/ Harness - Gasliter Control

S100 / ITB Tube & Reflector System

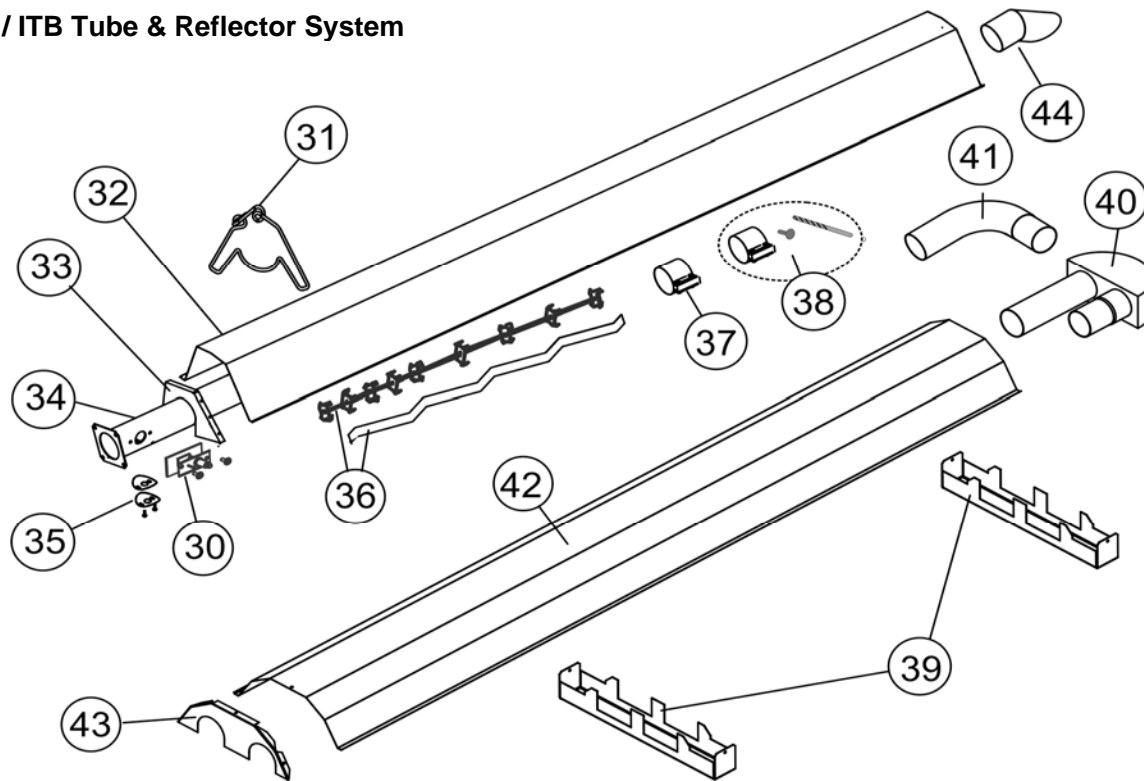

#	PART DESCRIPTION	MODEL	MODEL DASH #/ GAS TYPE	PART #	PART DESCRIPTION PRIMARY
30	IGNITER KIT			JA-0571-KT	Igniter & gasket kit / DSI tube heater
31	WIRE HANGER	<i>Straight Tube System</i>		JS-0505-EH	Small wire hanger
32	REFLECTOR	<i>Straight Tube System</i>		JS-0502-EM	Reflector (18" x 120")
33	END CAP	<i>Straight Tube System</i>		JS-0502-ES	S100 / ITB series reflector end cap
34	FLANGED TUBES	45 to 155		JS-0501-SW-P	Flanged, Aluminized Steel tube, swaged, ports
		175 & 200	<i>See next</i>	JS-0499-SW-P	Flanged, Alumitherm tube - DISCONTINUED
		175 & 200		JS-0500-SS-P	Flanged, Stainless Steel tube, swaged, ports; replaces JS-0499-SW-P
	SWAGED TUBES - NO FLANGE	175 & 200		JS-0501-SW	Aluminized tube, 10' with hole for rivet
		ALL		JS-0515-SW-P	Steel tube 10' swaged
		15' U-TUBE		JS-0515-SW-5	Steel tube 5' swaged
35	SIGHT GLASS ASSEMBLY	ALL		JS-0536-XX	Sight glass assembly tube heater
36	TURBULATOR (see Table 4 in Manual)	45 x 10 FT		JS-0534-SS	Turbulator 5' (7 PLATE)
				JS-0533-SH	Turbulator 4'
		TM-1430-SX		JS-0533-SS	Turbulator 5' - Stainless Steel
		TM-1430-SX		JS-0533-SL	Turbulator 8' - Stainless Steel
				JS-0533-LG	Turbulator 10'
		100		JS-0535-XX	Turbulator 10' Special - 100,000 Btuh ONLY
37	COUPLER	ALL		JA-0516-SW	4" swaged tube coupler torcite
38	COUPLER + STAINLESS STEEL RIVET + 1/4" DRILL BIT	175 & 200	1st to 2nd & 2nd to 3rd tube connections	JA-0516-RK	Tube Connection Kit: Coupler + Rivet + Drill Bit (175 & 200: 1st to 2nd & 2nd to 3rd tube)
39	DOUBLE STEEL HANGER	<i>U' Tube System</i>		JS-0505-BU	U tube reflector hanger
40	TURN BOX	<i>U' Tube System</i>		JS-0513-BU	U tube turn around box
41	90° ELBOW 4"		OPTIONAL	JA-0508-SW	90 degree elbow
42	DOUBLE REFLECTOR	<i>U' Tube System</i>		JS-0502-BU	Wide reflector 24" x 120" (10 ft)
43		<i>U' Tube System</i>		JS-0502-BU5	Wide reflector 24" x 60" (5 ft)
	U REFLECTOR END CAP	<i>U' Tube System</i>		JS-0502-ND	S100 / ITB series "U" reflector end cap
44	WALL VENT TERMINATION		OPTIONAL	JA-0528-XX	4" horizontal wall vent terminal
	COMPLETE TUBE KITS			Refer to Current Price List	GP-RS10-DX-03B S100 / ITB RPL RD-NOV 2014